

WARNING: CHECK FOR UNDERGROUND CABLES OR PIPES.
ADVERTENCIA: CHEQUE PARA CABLES O TUBOS SUBTERRÁNEOS.
AVERTISSEMENT: CHÉQUE POUR CÂBLES OU PIPES SOUTERRAINES.

RECOMMENDED TOOLS & SUPPLIES:
OUTILS & APPROVISIONNEMENT RECOMMANDÉS:
HERRAMIENTAS & ABASTECE RECOMENDADAS:

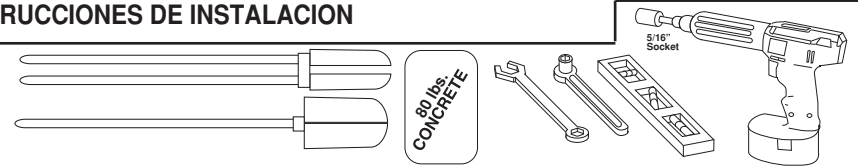

CORDLESS DRILL
 RECOMMENDED FOR
 SELF-THREADING
 SCREWS

PARTS / PARTIE / PARTES

- 1- Post
Poteau
Poste
- 1- Front Crossarm
Devant Bras de Croix
Frente Brazo de Cruz
- 1- Rear Crossarm
Queue Bras de Croix
Trasero Brazo de Cruz
- 1- Brace
Vilebrequin
Refuerzo
- 1- Finial
Casquette
- 1- Mounting Plate
Plaque
Placa
- 1- Anchor
Ancre
Ancla

**Hardware
Quincaillerie
Ferretería**

- 4- #10 x 3/4"
Pointed Self-Threading
Sheet Metal Screws
- 2- #10-24 x 3/4"
- 4- #10-24 x 1"
Unpainted
- 4- #10-24 x 1 3/4"
- 2- 1/4-20NC x 4 1/2"
- 4- 1/4 2- 1/4
- 4- White Plastic Washers

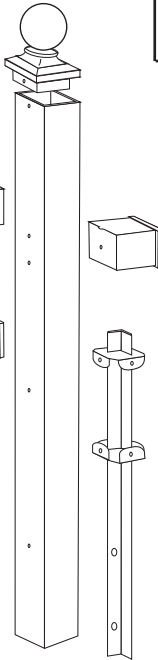

1 Attach anchor to post with 4 (#10 x 3/4") pointed self-threading sheet metal screws.

Attacher l'ancre à poteau avec 4 (#10 x 3/4") vis.
 Adjuntar ancla para poste con 4 (#10 x 3/4") tornillos.

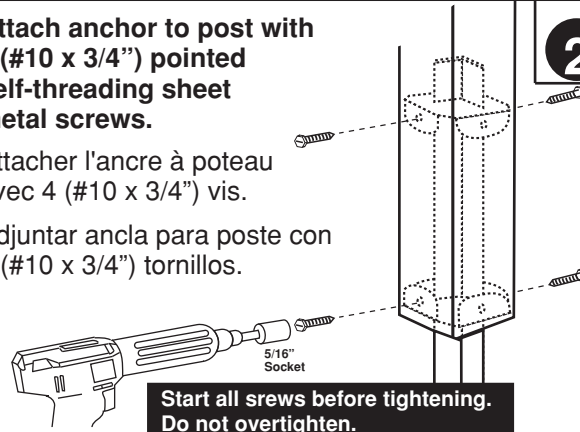

2 Dig a hole 20" deep and 9" in diameter. Fill with one 80 lb. bag mixture of concrete (follow manufacturer's instructions for mixing.) Place anchor and post in hole making sure holes in post face street. Level and allow to cure 24 hours.

Creuser un trou 20" profond et 9" dia. Remplir avec un mélange de un 80 lb. sac de béton et eau (suit le fabricant les instructions pour mélanger.) Endroit poteau et ancre dans le trou étant certain des trous dans la poteau visage la rue. Niveau et permettre établir 24 heures.

Excavar un hoyo 20" profundo y 9" dia. Llenar con un mescla de uno 80 lb. saco de concreto y agua (seguire fabricantes instrucciones para mezcla.) Lugar el poste y ancla en el hoyo asegurando hoyos en el poste hacia la calle. Nivel y permitir que coloque 18 a 24 horas.

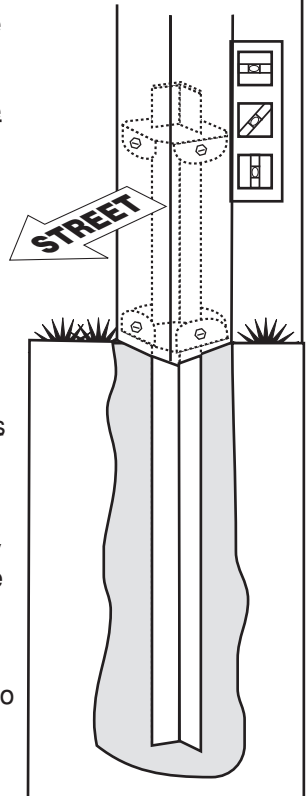

3 A. Attach front and rear crossarm to post with 1 (#1/4-20 x 4 1/2") bolt, washers and nut. B. Attach brace to crossarm and post with 1 (#1/4-20 x 4 1/2") bolt, washers and nut.

A. Attacher devant et queue bras de croix à poteau avec 1 (#1/4-20 x 4 1/2") verrou, lessiveuses et écroux.
 B. Attacher vilebrequin à bras de croix et poteau avec 1 (#1/4-20 x 4 1/2") verrou, lessiveuses et écroux.
 A. Adjuntar frente y trasero brazo de cruz para poste con 1 (#1/4-20 x 4 1/2") tornillo, arandelas y tuerca. B. Adjuntar refuerzo para brazo de cruz y poste con 1 (#1/4-20 x 4 1/2") tornillo, arandelas y tuerca.

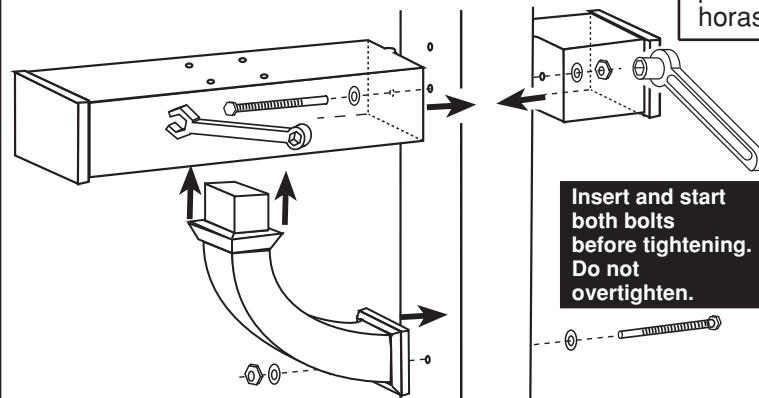

4 Attach finial to post with 1 (#10-24 x 3/4") self-thread screw.

Attacher casquette à poteau avec 1 (#10-24 x 3/4") vis.
 Adjuntar finial para poste con 1 (#10-24 x 3/4") tornillo.

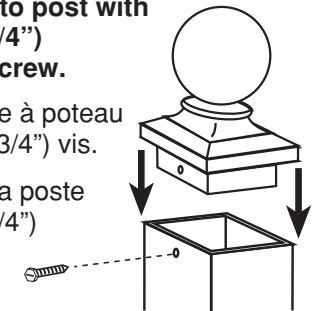

5 Attach mounting plate to crossarm with 4 (#10-24 x 1") self-thread screws.

Attacher plaque à bras de croix avec 4 (#10-24 x 1") vis.

Adjuntar placa para brazo de cruz poste con 4 (#10-24 x 1") tornillos.

Start all screws and align with crossarm before tightening. Do not overtighten.

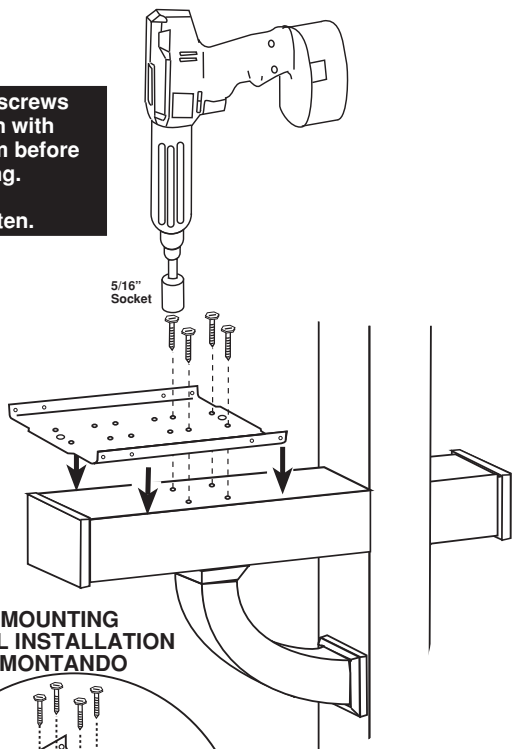

**OPTIONAL MOUNTING
OPTIONNEL INSTALLATION
OPATIVO MONTANDO**

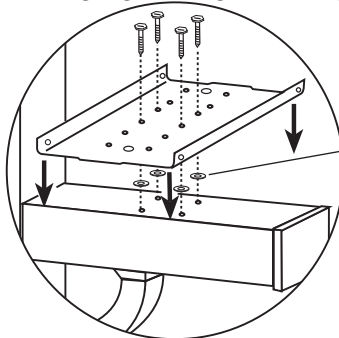

Use white plastic washers

Employer des lessiveuses plastiques blanches.

Usar arandelas plásticas blancas.

6 Attach mailbox to mounting plate with 4 (#10-24 x 1 3/4") self-thread screws.

Attacher boîte aux lettres à plaque avec 4 (#10-24 x 1 3/4") vis.
Adjuntar buzón para placa con 4 (#10-24 x 1 3/4") tornillos.

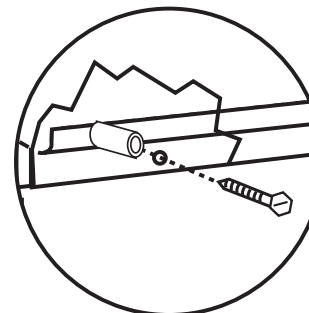

NOTE: Spacers are provided to mount a larger (T2) size mailbox.

L'ANNOTATION: Les adaptateurs sont fournis à attacher une boîte aux lettres plus grande.

NOTA: Los adaptadores se proveen para adjuntar un buzón más grande.

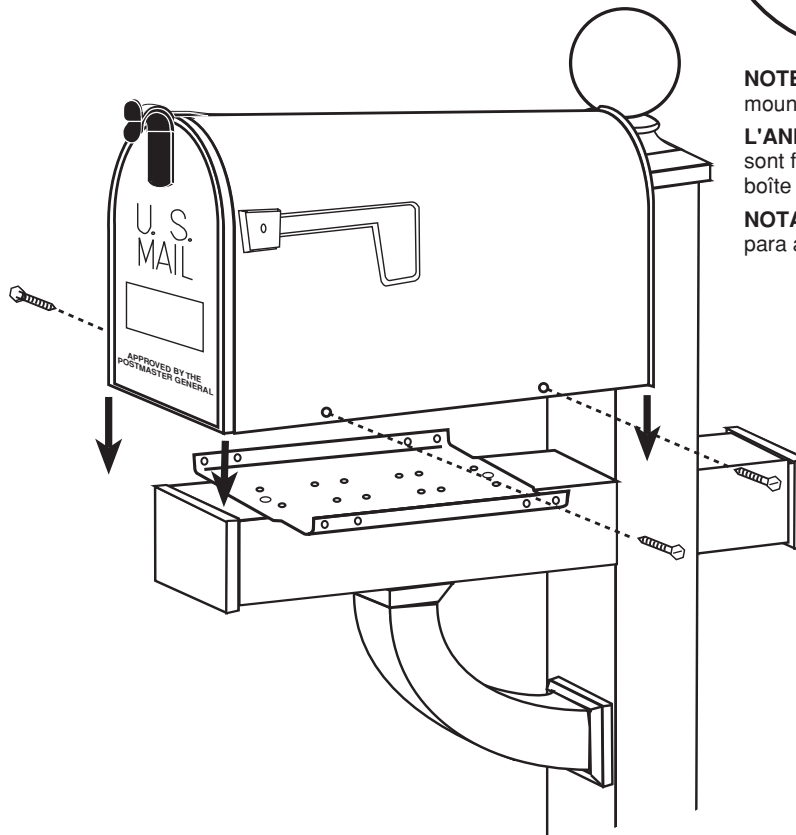

Start all screws before tightening. Do not overtighten.

10 Year Warranty

Solar Group, Inc. warrants this mailbox product to be free from defects in materials and workmanship for a period of ten years from the purchase date by the original purchaser. This limited warranty does not include minor cosmetic blemishes caused by normal use, environmental conditions which may cause coating, fading, chipping or damage caused by others. Solar Group, Inc. shall not be liable under this or any implied warranty for incidental or consequential damages. This warranty does not cover any mailbox product which has been altered or used for a purpose other than that for which it is intended, or manner inconsistent with any instructions regarding its use or installation. This warranty shall be limited to repair or replacement of product or parts found to be defective under normal use, as determined by Solar Group, Inc.

SOLAR GROUP Inc.
A GIBRALTAR COMPANY

P.O. Box 525
Taylorsville, MS 39168

AR30055-03